

No.	Description	Mat's	Quantity	Remark
1012	Foot-L assy		1	
1013	Foot-R assy		1	
2021	Front foot cap		2	
2022	Rear foot cap		2	
2025	Cover-L		1	
2026	Cover-R		1	
2028	Sticker-L		1	
2029	Sticker-R		1	
2042	Front foot cap bush		2	
3002	1-round key		4	
4001	Load controller		1	
4002	Monitor		1	

Caution label(2048)

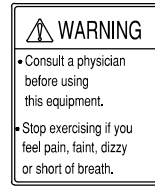

Warning label-#1(2054)

Warning label-#2(2051)

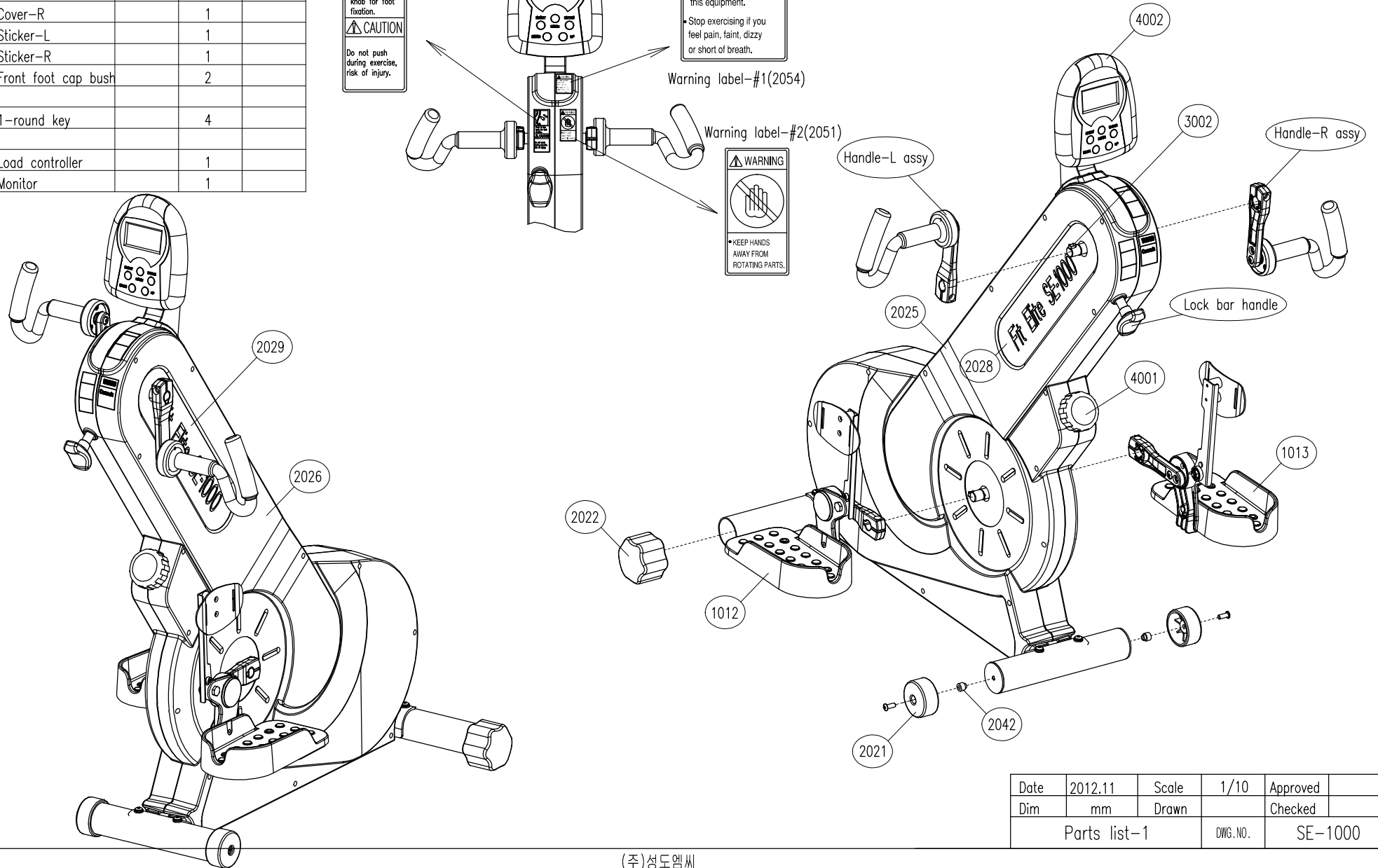

Date	2012.11	Scale	1/10	Approved	
Dim	mm	Drawn		Checked	
Parts list-1			DWG. NO.	SE-1000	

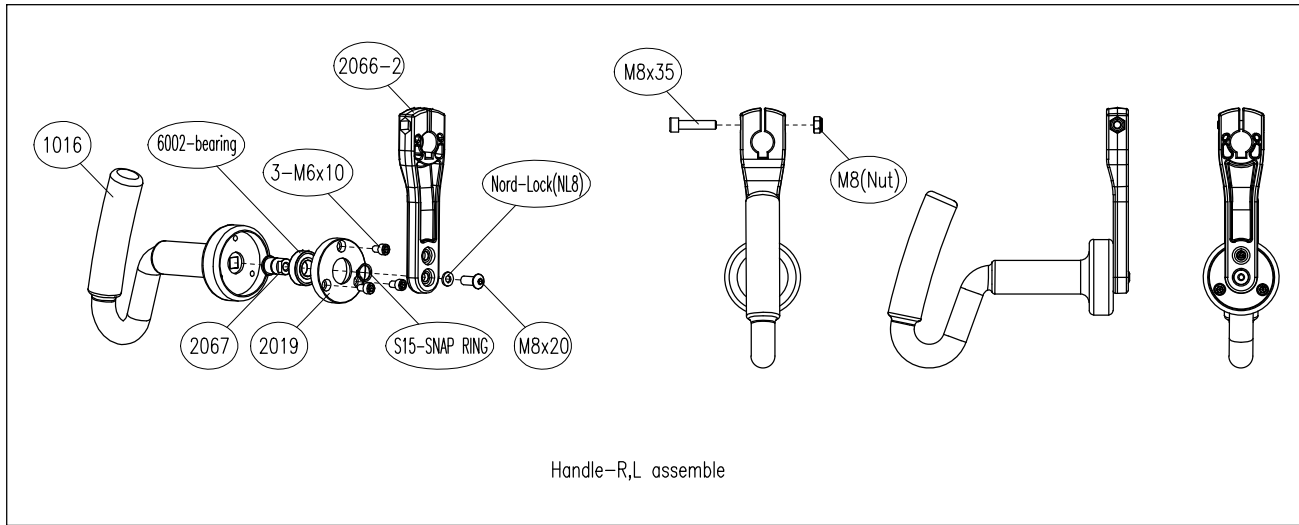

Handle-R,L assemble

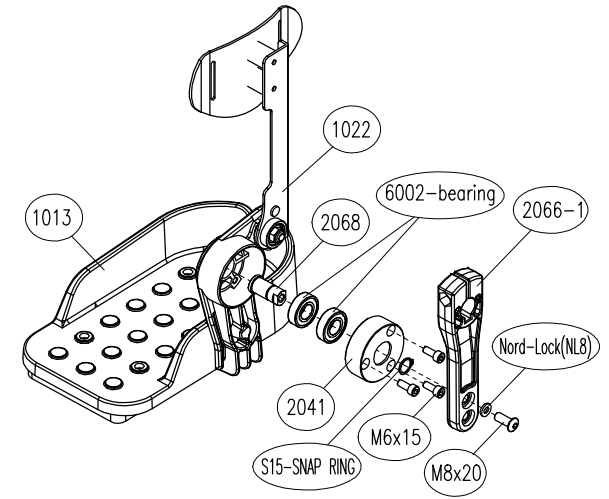

Pedal-R assemble

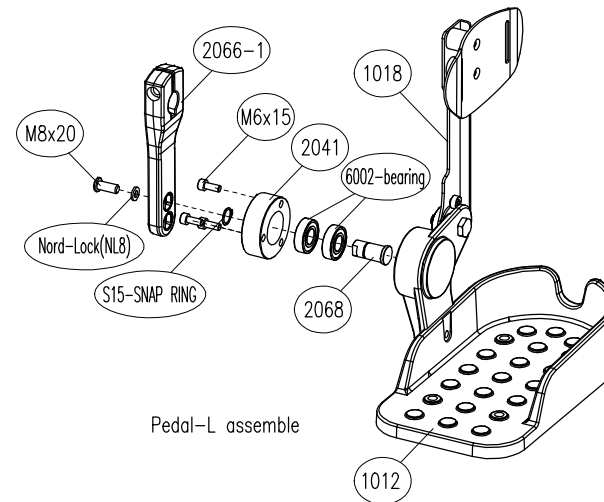
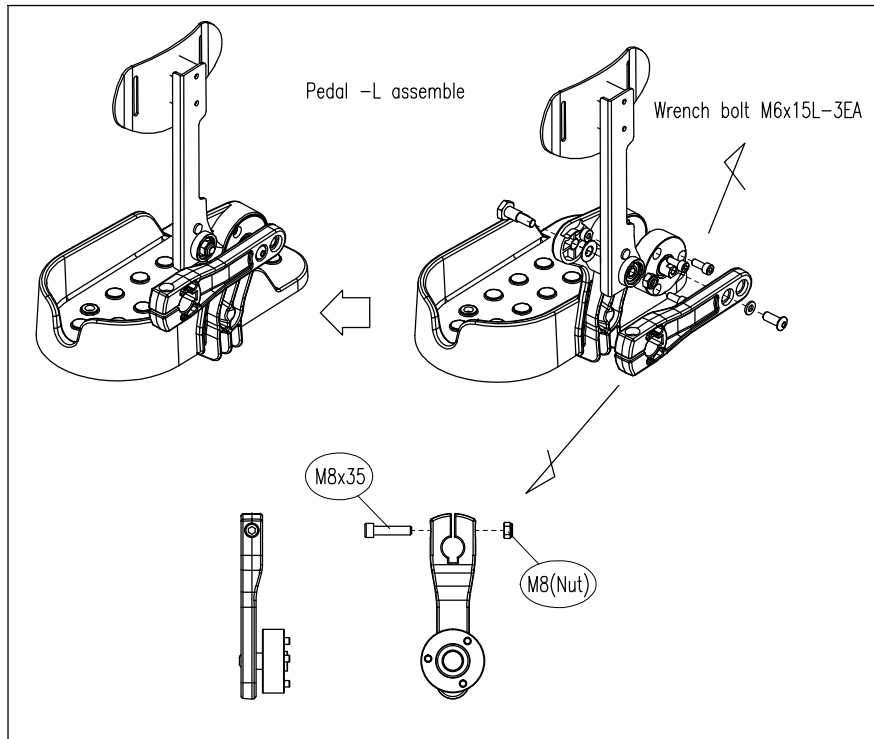

Pedal-L assemble

2068	Lower crank shaft-R,L		2	
2067	Upper crank shaft-R,L		2	
2066-2	Upper crank-R,L		2	
2066-1	Lower crank-R,L		2	
2041	Lower bearing housing		2	
2019	Upper bearing housing		2	
1022	Foot stick assy-R		1	
1018	Foot stick assy-L		1	
1016	Handle-urethane		2	
1013	Pedal-R assy		1	
1012	Pedal-L assy		1	
No.	Description	Mat's	Quantity	Remark
Date	2012.11	Scale	1/7	Approved
Dim	mm	Drawn		Checked
Parts list-2		DWG. NO.	SE-1000	